



PANEDA KEY FEATURES

DAB Multiplexing System version 2021-06-16

Summary

Paneda develops DAB head-end systems and is today a world leader in the area. The flexible generic system is developed with the most modern technology and has several unique features, such as state-of-art redundancy mechanisms using the unique Paneda SMART content switching. Another important area is security, which means that all connections internally and externally are encrypted using TLS/HTTPS. The security has been tested by third party security companies and is graded as A+, the highest possible security level. Easy integration with third party products for contribution, meta data and distribution are also in focus. Paneda uses open API's such as JSON based RESTful API.

Subject for changes without further notice

ABOUT THE PANEDA DAB MULTIPLEXING SYSTEM

General

Paneda has developed a completely new head end system from scratch, based on almost 20 years' experience and based on customer's feedback from over 200 installations worldwide. The system is using the most modern architecture and using restful API's with highest security in focus. The system was released in its first version during 2015 and have been further developed according to new requirements in the DAB standard and input from customer needs.

The Paneda DAB software solution has many advantages vs. a hardware solution, such as generic, further development and expansion of the system with possibility to install on any hardware platform, OS independent, which means a non-vendor lock-up.

The Paneda DAB Head-End solution can mainly be realised in three setups, described below, using the exact same software system, but with different approaches:

We recommend the setup 2, the server version. This setup offers a future proof solution where you easily can add more stations and new multiplexers at any time, using the same hardware! For redundancy, we encourage this by providing high discounts.



HARDWARE This is the traditional setup with dedicated hardware units. Paneda has developed a 1U embedded Linux system, and in one single 1U you can install a complete system with multiplexer, data management, up to 16x encoders built in per unit. Maximum **physical** inputs are 8x AES/EBU per 1U, the rest must be in IP format.

In addition, Paneda also have a standalone hardware encoder with 3 built in DAB/DAB+ Encoders.



SERVER version (recommended)
The Paneda system installed in a standard server, provided by Paneda or in **your** existing environment. Benefits is that it is a standard hardware and easy to migrate to any new server in the future. The system uses VMware as virtual system with Linux operating system for the multiplexing system. The very same server can host **several** multiplexers and a large number of encoders.



CLOUD version.
This means that the system is installed in a datacentre somewhere, like Google datacentre in UK, Netherlands, or Ireland or in any other place you prefer. The functionality is 100% the same, you use web interface to manage the complete system. In this setup, the encoders must receive audio from your stations, and this can either be using HQ audio streams from your web radio server or dedicated streaming encoders or using a Paneda remote DAB encoder as well.

FOCUS AREAS

SECURITY



The system supports:

Encrypted connections where applicable, for example when using metadata. It will not be possible for unauthorized party to manipulate metadata such as text or pictures.

- Usage of a secure user database, all registered users must use real email addresses with a password selected by themselves. The passwords are individually salted and hashed for storage according to best practice.
- Defined custom user rights and different roles in the system, no limitations to number of users
- 2 factor authentications
- Web interface for management support HTTPS/SSL with valid certificates
- Security level A+ ranked

REDUNDANCY

Broadcast systems requires a very high availability and much focus has been on redundancy and back-up. Paneda has developed new features that offers a new and higher level of redundancy.

AUDIO:

The Paneda audio handling is service oriented where a service refers to a matrix of selectable audio sources, and in combination with redundant audio sources this ensures a more fault tolerant audio handling.

- A service points to an audio source rather than an audio encoder, providing best flexibility without changing encoder when changing audio source
- Each audio input can be defined with multiple audio sources, as web streams, as fallback or playing an audio file
- All defined audio inputs are “hot” and monitored. An audio switch-over will not be performed to a non-working audio.
- A service can at any point referring to any available audio source.

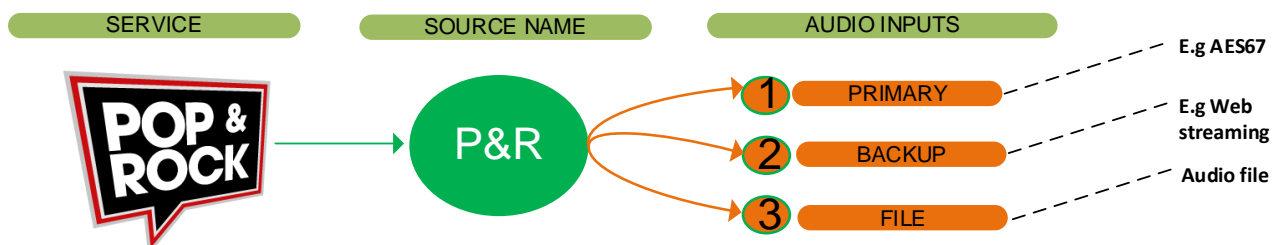

SMART CONTENT SWITCH

The unique Paneda system has a smart content switching using “patching” of two faulty signals. One audio error in one mux, another audio error in the redundant mux, generates an error free output.

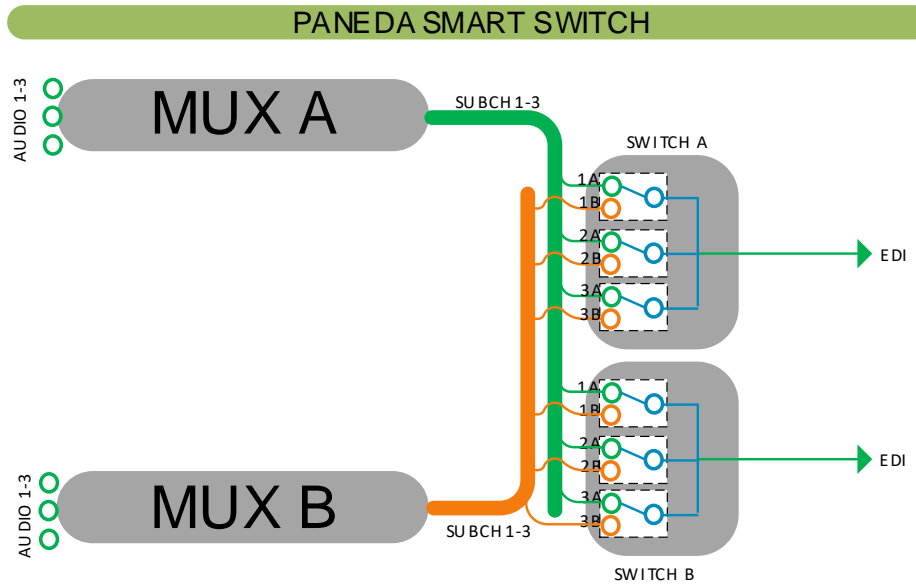

Paneda subchannel switch, example with 3 subchannels.

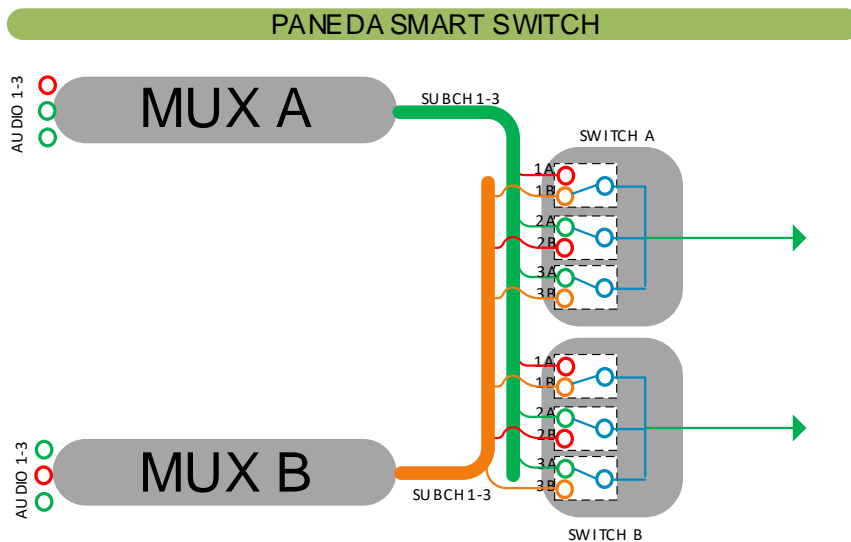

Picture showing multiple errors, service 1 has failed in the main system, service 2 has failed in the redundant system. Both services OK on output of both systems

SYNCHRONIZATION with PFT (Protection, Fragmentation and Transport)

Multiplexer redundancy including PFT synchronization of configuration AND multiplexer output frame synchronization. Multiplexers in redundant mode are 100% synchronized to enable seamless switching on EDI level in the transmitters or in the IP network.

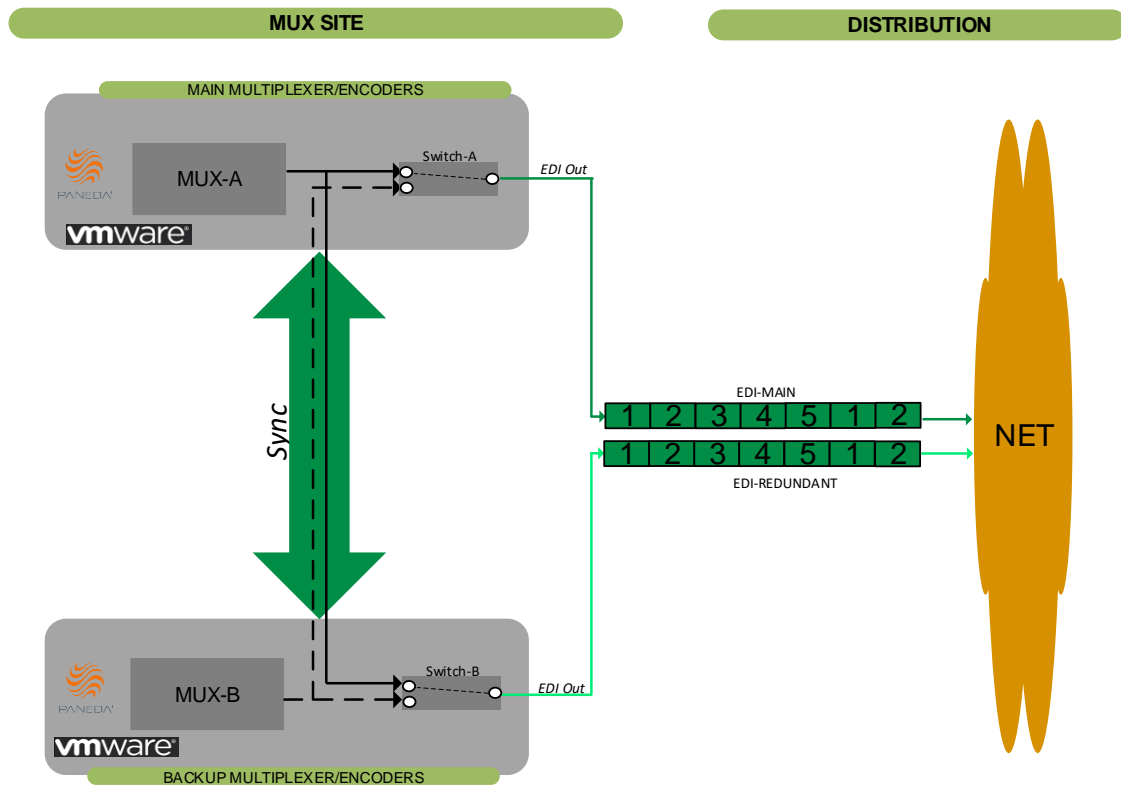

*Paneda output are synchronized and PFT aligned, means that each PFT fragment contains the **exact** same data.*

SYNCHRONIZATION WITH TIMESHIFT

In addition to PFT synchronization, the Paneda also supports time shifting of the outputs, this provides a higher level of redundancy on the distribution network.

- On a network drop-out, a time shifted output ensures that different data is affected at the same time.
- A receiver supporting PFT handling can cherry picking fragments from either stream.

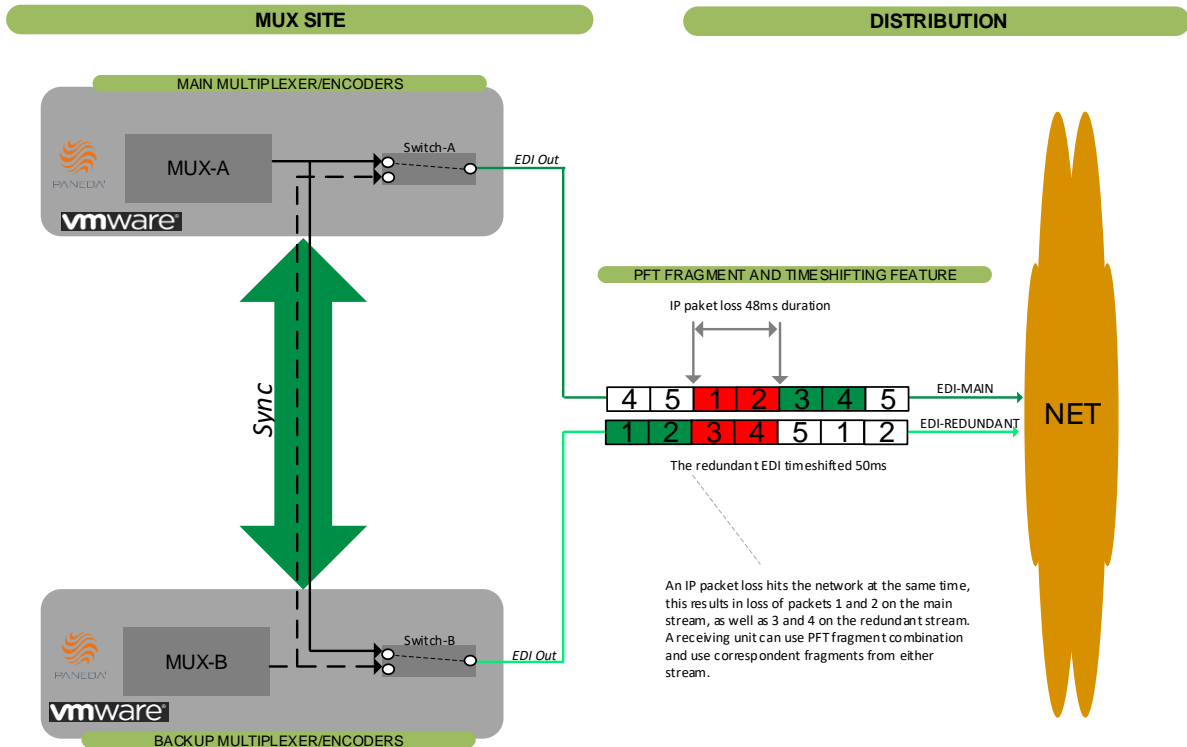

Network drop out affect different data content on the two streams.

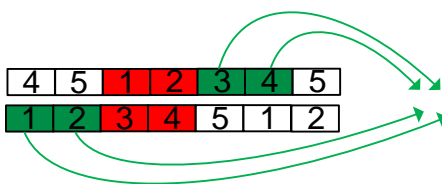

An EDI receiver can cherry picking individual PFT fragments from either stream

PROVIDERS

The system supports a flexible way to handle different providers. Each provider may login to the system and manage their own specified capacity range, totally isolated and independent from each other. This handling replaces the older *service multiplexer* handling and have eliminated the disadvantages of such setup.

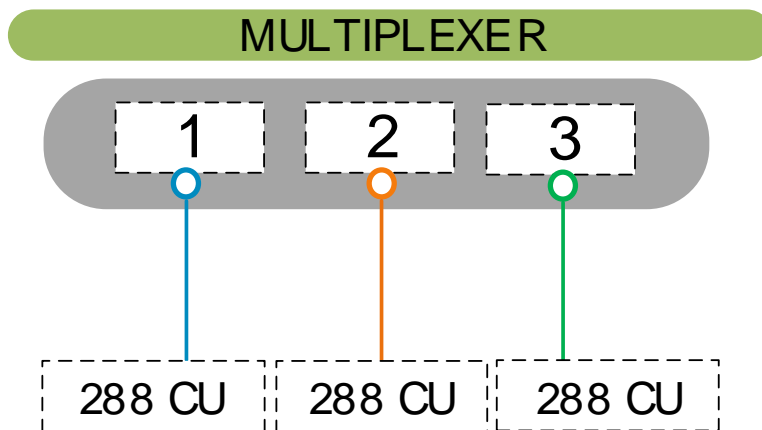

The multiplexer can be divided into capacity slots, one for each provider. Each provider has access to their own capacity slots. Each provider uses their own web interface for managing the system. Each provider is 100% isolated from the other.

METADATA

- The system supports adding text/pictures directly in the web interface
- Insertion of metadata as text and picture easy integrated, using web-based API as JSON
- Insertion of metadata is encrypted and requires an access code to prevent manipulating of metadata

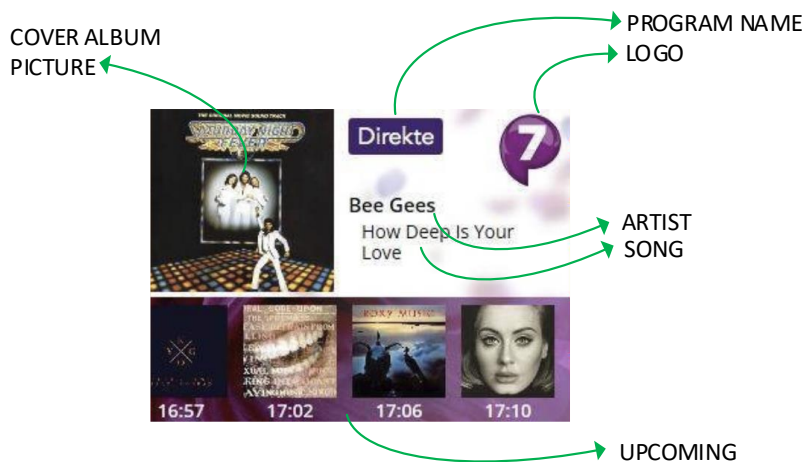

SLS Example showing a dynamic information of artist, song and more.

VIRTUALIZATION

The Paneda system is designed to be virtualized. Using a server with VMware it's possible to install several DAB multiplexer systems and encoders in the very same hardware. Each system is independent and installed in its own guest operating system.



Supported features

Audio/Metadata

- The system supports 64kbps with PS+SBR (only Fraunhofer codec supports this feature)
- A service points to an audio source rather than an audio encoder providing best flexibility without changing encoder when changing audio source.
- Each audio input can be defined with multiple audio sources, as web streams as fallback or even playing an audio file.
- Supports an easy way to insert audio from remote sites
- Insertion of metadata as text and picture easy integrated, using web-based API as JSON.
- Supports adding text/pictures directly in the web interface
- Alarms if no metadata is present

Monitoring

- Custom defined SNMP channels
- Monitoring via the Paneda API, support for major monitoring systems like DataMiner and more.
- The web interface supports real-time status overview of the system, including real-time VU meters
- All activities in the system logged in an audit log

General system support and functions

- Only web-based interface is required for settings/controlling and monitoring no config files or other methods required
- The system (web interface) uses and support TLS (SSL) for highest security including 2factor authentication.
- Supports multiple languages
- Support for local language in the web interface
- Remote support in an easy way
- The complete system is built to be realized in a VMware setup
- The system uses Linux as operating system (non-Windows OS)
- The system is scalable in the way that a new service/new provider or even a new complete system can be started without hardware investments
- Supports service following between DAB-FM, and supporting the latest standard “linkage actuator”
- Support for measurement of audio levels (VU meters) in the web interface
- Custom FIG signalling supported
- Support for other codecs (as Open source codec)
- Seamless changing of bitrate of a service as well as changing codec
- Support for using Web radio streams as audio source like shoutcast/icecast and other commonly used formats for web radio
- EDI input support including support for “re-multiplexing” and subchannel based extraction.
- Support for using mobile phone for controlling/monitoring in such way that the web interface is developed to be scalable for mobile devices.
- Support for the All-In media “RAPID” content system
- 1+1 redundancy including synchronization of configuration AND multiplexer output frame synchronization
(Multiplexers in redundant mode 100% bit synchronized to enable seamless switching on EDI level in the transmitters or in the IP network)

TECHNICAL FEATURES

AUDIO ENCODER	INCLUDED	OPTION
Open source codec MP I/II & AAC	•	
Support for AES67/Livewire	•	
Support for AES/EBU		○
Support for streaming formats, Iccast/Shoutcast e.tc	•	
Audio input redundancy, multiple sources		○
Support for Fraunhofer PRO AAC codec	•	
Support for external encoders	•	
Audio input as file, mp3 or wav	•	
Drift compensation for web streams	•	
Silence detector	•	
Gain control	•	
VU meter real-time	•	
Seamless changes of audio parameters	•	
Hardware external encoder		○

MULTIPLEXER	INCLUDED	OPTION
EDI Input re-multiplexing	•	
Full EDI standard implementation	•	
Multiple EDI outputs	•	
Individual settings of EDI outputs	•	
EDI PFT synchronization	•	
EDI PFT address field support	•	
Advanced Configuration Scheduler	•	
Service following FIG 0/6	•	
Linkage actuator	•	
Frequency Information FIG 0/21	•	
Other Ensemble FIG 0/24	•	
FIG editor	•	
ETI recording at output		○
Virtual Service Provider	•	
SMART Content Switch		○
Seamless built in EDI switch		○
Graphical performance monitor	•	
Announcement support	•	

SECURITY	INCLUDED	OPTION
Built in firewall	•	
HTTPS (SSL) encryption	•	
Certificate handling	•	
2 factor authentications	•	
Internal and external connections encrypted	•	
User database with custom user rights	•	
User audit log	•	

DATA	INCLUDED	OPTION
DLS	•	
DL+	•	
SLS	•	
EPG		○
TPEG		○
Support for external content systems as Rapid	•	
Alarm on no metadata	•	
Backup metadata on no content	•	

GENERAL	INCLUDED	OPTION
All language support	•	
Mobile friendly GUI	•	
JSON web API	•	
SNMP custom defined	•	
100% web interface for setup and management	•	
Remote tunnel for support and upgrades	•	
Backup&restore from GUI	•	
Virtualization support for VMware	•	
Realtime status monitoring in web interface	•	
Support for manage 3rd party system web interface	•	
Realtime status monitoring in web interface	•	
Graphical event log overview	•	
Unlimited number of users	•	

EXAMPLE PRINT SCREENS

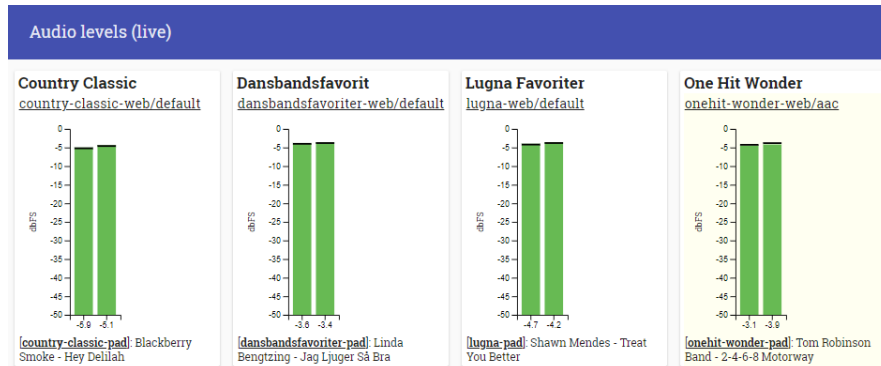

AUDIO STATUS OVERVIEW WITH PAD DATA.

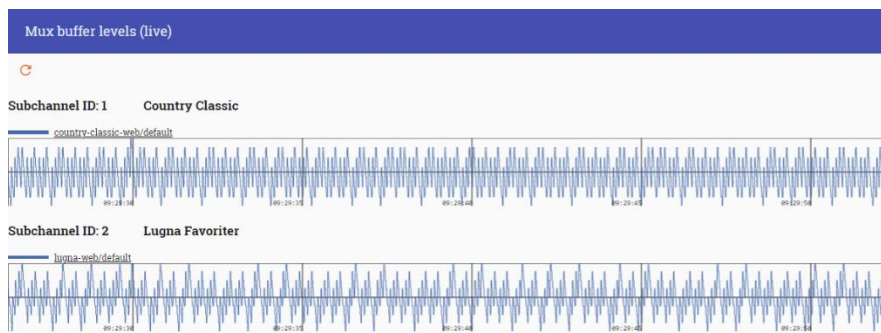

REAL TIME BUFFER LEVEL STATUS



GRAPHICAL ALARM HISTORY LOG

Performance monitor

PERFORMANCE MONITOR

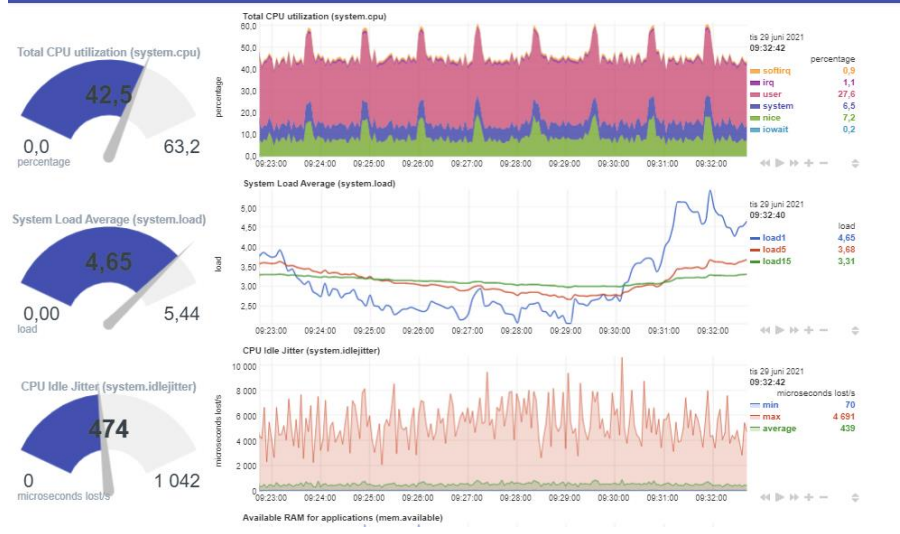

Preview

month week day

June 2021

Sun	Mon	Tue	Wed	Thu	Fri	Sat
30	31	1	2	3	4	
6	7	8	9	10	11	
13	14	15	16	17	18	
20	21	22	23	24	25	
27	28	29	30	1	2	

Calendar view showing on-air schedules for June 29th and 30th, 2021. Schedules are listed in 15-minute intervals (e.g., 09:10 on-air, 09:25 on-air, etc.).

CALENDER BASED SCHEDULER

Audit log

1 2 3 4 5 6 7 8 9 10 50

When	By	Action	Name	Changes
8 minutes ago	lars-peder.lundgren@paneda.se	user-authentication	login	
3 days ago	lars-peder.lundgren@paneda.se	reconfiguration	NENT Small 2021-05-31	
3 days ago	lars-peder.lundgren@paneda.se	system-configuration-updated	ensemble	CLICK TO VIEW CHANGES
3 days ago	lars-peder.lundgren@paneda.se	user-authentication	login	
7 days ago	lars-peder.lundgren@paneda.se	remote-access-changed	tunnels-closed	
7 days ago	lars-peder.lundgren@paneda.se	remote-access-changed	tunnels-opened	
7 days ago	marcus.lundgren@paneda.se	service-conf-updated	NENT Small 2021-05-31	CLICK TO VIEW CHANGES

AUDIT LOG PER USER

Language settings

Language	Locale	Enabled
Chinese	zh	✓
Czech	cs-CZ	✓
Dutch	nl	✓
English	en	✓
French	fr	✓
German	de	✓
Italian	it	✓
Norwegian	no	✓
Polish	pl-PL	✓
Russian	ru	✓
Serbian	sr	✓
Spanish	es	✓
Swedish	sv	✓
Thai	th-TH	✓
Vietnamese	vi	✓

[UPDATE LANGUAGE PACKAGE](#)

Installed Language pack version: "1.2021.05.31.r659-1"

MULTI LANGUAGE SUPPORT

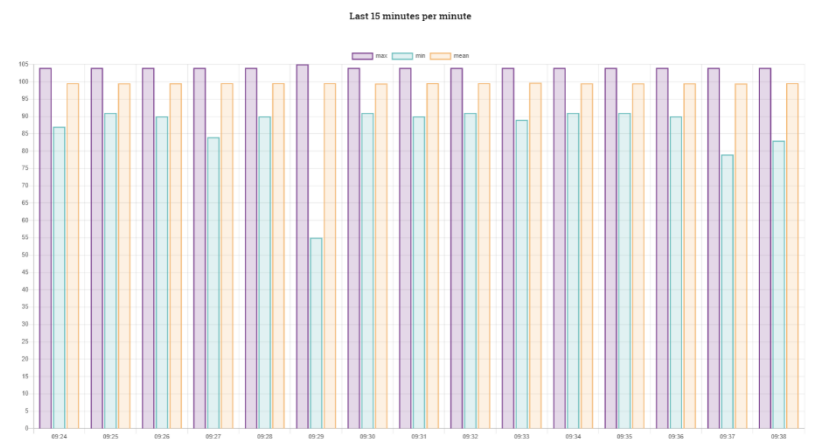

OUTPUT BUFFER STATUS OVERVIEW